



# Lithiumate™ EL02

## Li-Ion BMS controller processor

### Features

- Powered by the load (e.g. a motor controller) or by the source (e.g.: a charger)
- Controls up to 255 cell boards, in up to 16 banks
- Measures the cell voltages and cell board temperatures
- Controls cell balancing
- Calculates DOD, SOC, resistance and SOH
- Reports status to external system:
  - CAN bus
  - RS232
  - Hard lines
- Fully programmable through a standard RS232 terminal (no software required)
- Fan and contactor drive

### Applications

- Vehicle traction packs
- Li-Ion UPS batteries
- Large Li-Ion battery packs

Not to be used in military nor life support applications.

### Typical application

A BMS consists of one BMS controller (using an EL02) and cell-boards for between 1 and 255 cells in series, with one EL01 for each cell in series.



### Description

The EL02 is a programmed micro-controller that forms the core of an Elithion Li-Ion BMS controller. It communicates with cell boards mounted on Li-Ion cells. It manages the battery by controlling cell balancing and requesting the external system to reduce or stop charging and/or discharging. It communicates with the external system reporting status of the battery. It may control precharge contactor and a cooling fan.

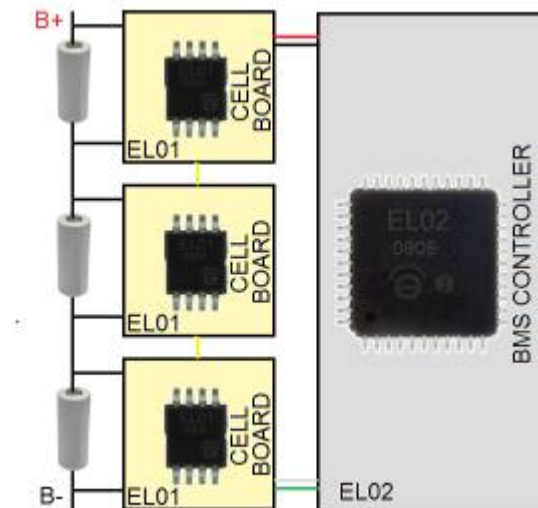



### Absolute maximum ratings

Vdd supply voltage	7.5	V
Vpp voltage	13.25	V
All other pins, pos voltage	Vdd +0.3	V
All pins, neg voltage	-0.3	V
Total power dissipation	1	W
Vss out current	300	mA
Vdd in current	250	mA
Port clamp current	±20	mA
Port sink current	25	mA
Port source current	25	mA
Total port sink current	200	mA
Total port source current	200	mA
Temperature	-40°C to +85	°C

### Pin-out

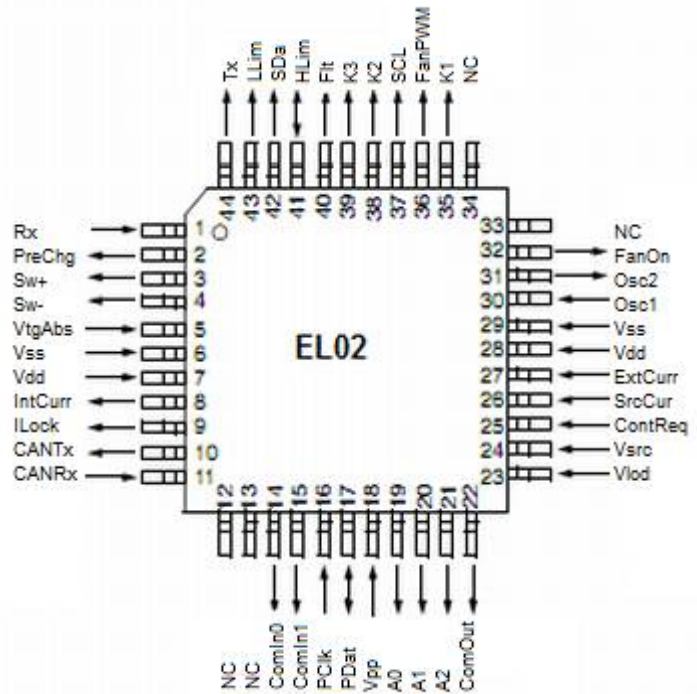

### Ordering info

Format	Part number	Package	Temper. range	Order qty
Tube	EL02	TQFP-44	-40°C to +85°C	Any

**Electrical characteristics**

Unless otherwise noted, 5.0 Vdc, 25 °C.

Symbol	Parameter	Conditions	Min	Nom	Max	Units
V <sub>supply</sub>	Supply voltage		4.5		5.5	V
V <sub>range</sub>	Cell voltage sensing range		2.09		4.54	V
V <sub>resol</sub>	Cell voltage sensing resolution			10		mV
V <sub>accur</sub>	Cell voltage sensing accuracy	Within V <sub>range</sub>		±10	±15	mV
V <sub>temp-err</sub>	Cell voltage sensing error over temp	Within V <sub>range</sub> -20 to +60°C		+2 / -7	±18	mV
		Within V <sub>range</sub> Charging range: 0 to +60°C		±2	±17	mV
I <sub>sply</sub>	Cell drain current	Stand-by			2	µA
		Active, 1-reading / sec		1.5	2.0	mA
T <sub>range</sub>	Temperature sensing range		-99		+99	°C
T <sub>accur</sub>	Temperature sensing accuracy			±2		°C
F <sub>comm</sub>	Communication rate			5		kBaud



## Pin functions

#	Name	Dir.	Function	#	Name	Dir.	Function
1	Rx	In	RS232 receive	23	Vlod	In	Load supply voltage
2	PreChg	Out	*	24	Vsrc	In	Source supply voltage
3	Sw+	Out	*	25	ContReq	In	Contactora request
4	Sw-	Out	*	26	SrcCur	A/D	Source current sense
5	VtgAbs	In	*	27	ExtCur	A/D	External current sense
6	Vss	Power	Ground	28	Vdd	Power	5 V power
7	Vdd	Power	5 V power	29	Vss	Power	Ground
8	IntCurr	A/D	Internal current sense	30	Osc1	In	Oscillator
9	Ilock	In	Interlock	31	Osc2	Out	Oscillator
10	CANTx	Out	CAN transmit	32	FanOn	Out	Fan drive
11	CANRx	In	CAN receive	33			
12				34			
13				35	K1	Out	Precharge relay drive
14	ComIn0	In	*	36	FanPWM	Out	Fan PWM
15	ComIn1	In	*	37	SCL	Out	I2C clock
16	P.Clk	In	Programming clock	38	K2	Out	Positive contactora drive
17	P.Dat	I/O	Programming data	39	K3	Out	Negative contactora drive
18	Vpp	In	Programming voltage	40	Flt	Out	Fault output
19	A0	Out	*	41	Hlim	Out	Fault output
20	A1	Out	*	42	SDA	I/O	I2C data
21	A2	Out	*	43	Llim	Out	Fault output
22	ComOut	Out	*	44	Tx	Out	RS232 transmit

(\*) Elithion intellectual property, only available to qualified clients.

## Theory of operation

[Elithion intellectual property, only available to qualified Elithion clients.]



## **Application information**

### **Oscillator**

A 10 MHz crystal is placed across the Osc1 and Osc2 pins. 15 pF capacitors are placed from those pins to ground.

### **CAN port**

In order to connect to the CAN bus, a CAN buffer is required, such as the MicroChip MCP2551. The buffer is connected to the CANTx and CANRx pins. A CAN bus termination may be included on board, and, in that case, a means to selectively turn it on may be included as well.

### **Rs232 serial port**

In order to connect to a serial port, a RS232 buffer is required, such as the MAX202. The buffer is connected to the Tx and Rx pins. Such buffers typically include voltage triplers to generate the + and - 15 V rails from the 5 V supply, using 4 capacitors. The only connections needed to a DE-9 connector are:

- pin 2: TX output
- pin 3: RX input
- pin 5: ground

The serial port is normally used to program the controller's functionality.

### **Programming port**

A 5-pin socket can be included to enable reprogramming the device, or to back-up and restore the EEPROM contents. There is no standard for that socket, but the following pinout will make the BMS controller compatible with the TeaClipper programmer from FlexiPanel.

1. Vdd
2. Pdat
3. Pclk
4. Vpp
5. Gnd (to Vss)

There is no need for any pull-up / pull-down resistors for programming, though a 10 kOhm resistor on the Pdat pin will enable the test program to detect the presence of a test fixture (which shorts the Pdat and Pclk pins together).

This port may be used to pre-program the functionality of many controllers:

- Program a master controller as desired
- Use a programming device to read the EEPROM and save to a file on a computer
- Use the programming device to write the EEPROM of the many controllers.

### **Current sense**

The controller has 3 analog inputs to sense battery current.

- IntCurr - to measure the battery current with an on-board sensor
- SrcCur - to measure the current between the source and the battery



- ExtCur - to measure the current between the load and the battery

The input voltage range is 0 to 5 V, and the resolution is 10 bits. The offset and the scaling factor are programmable by the user. Which current sensor is used when powered by a given input is also programmable.

### **Relay drivers**

The purpose of the K1, K2 and K3 outputs is to drive 3 relay drivers for the precharge relay, positive contactor and negative contactor, respectively

### **Status outputs**

The Fit, H.Lim and L.Lim outputs are activated when there is a fault, a cell is fully charged, and a cell is fully discharged, respectively. Their polarity and the thresholds that result in their activation are all programmable.

### **Intelock input**

This input is intended for a switch that, when activated, it will cause a fault and shut down operation. Its polarity is programmable.

### **Fan outputs**

The Fan output is activated when the temperature of the cell boards exceeds a programmable set-point. It is intended to control a power driver stage to power a fan off and on.

The Fan PWM output is intended for a driver for a variable speed fan. Typically it would drive a MOSFET, with a fly-back diode to V+, which in turn would drive a DC fan. This output has a 20 kHz square wave, whose duty cycle is 0 % below that set-point, and increases above 0% as the temperature rises, until it reaches 100 % at a programmable max temperature.

### **I2C lines**

These lines are used to control a DAC5574 quad D/A converter. Its generates 0 to 5 V outputs:

- VoA: CCL (Charge Current Limit): normally 5 V, down to 0 V as the most charged cell reaches its maximum voltage
- VoB: DCL (Discharge Current Limit): normally 5 V, down to 0 V as the most discharged cell reaches its minimum voltage
- VoC: SOC (State Of Charge): normally 5 V, down to 0 V as the battery gets discharged
- VoD: pack current: normally 2.5 V with no battery current, down to 0 V as the charging current increases, or up to 5 V as the discharging current increases.

### **Bank communications**

This circuit uses the following lines: A0, A1, A2, ComIn0, ComIn1, ComOut. The operation of this circuit is Elithion's intellectual property and is only available to qualified clients.

### **HV front end interface**

This circuit uses the following lines: PreChg, Sw+, Sw-, AbsVtg. The operation of this circuit is Elithion's intellectual property and is only available to qualified clients.



**Suggested circuit**

[Elithion intellectual property, only available to qualified Elithion clients.]





## Packaging information

### 44-Lead Thin Quad Flat Pack [TQFP]

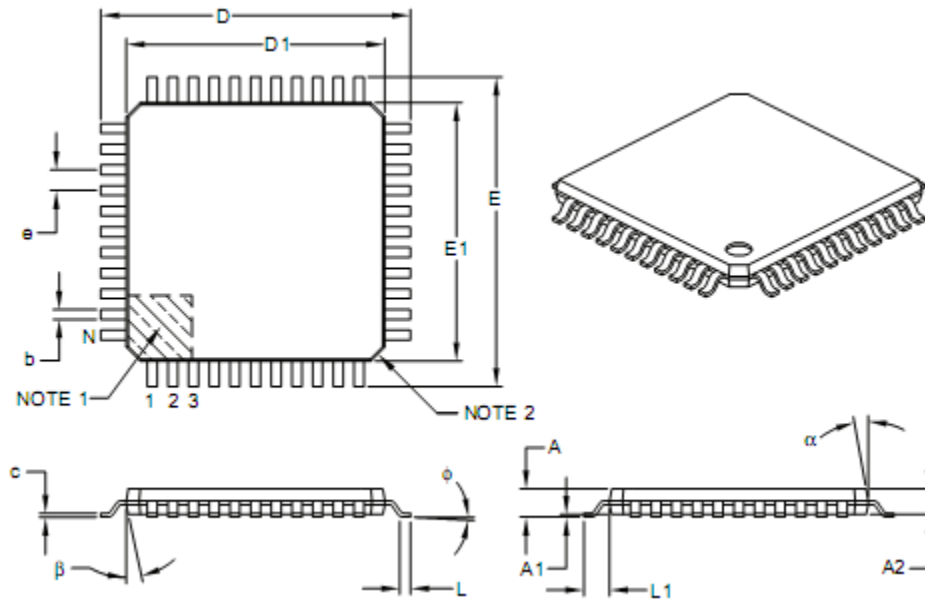

	UNITS: mm	MIN	NOM	MAX
Number of Pins	N		44	
Pitch	e	0.80 BSC		
Overall Height	A	-	-	1.20
Molded Package Thickness	A2	0.95	1.00	1.05
Standoff	A1	0.05	-	0.15
Overall Width	E	12.00 BSC		
Molded Package Width	E1	10.00 BSC		
Overall Length	D	12.00 BSC		
Molded Package Width	D1	10.00 BSC		
Foot Length	L	0.45	0.60	0.75
Footprint	L1	1.00 REF		
Foot Angle	$\phi$	0°	3.5°	7°
Lead Thickness	c	0.09	-	0.20
Lead Width	b	0.30	0.37	0.45

**Notes:**

1. Pin 1 visual index feature may vary, but must be located within the hatched area.
2. Chamfers at corners are optional; size may vary.
3. Dimensions D1 and E1 do not include mold flash or protrusions which shall not exceed 0.15 mm per side.
4. Dimensioning and tolerances per ASME Y14.5M.

BSC: Basic Dimension. Theoretically exact value shown without tolerances.

REF: Reference Dimension, usually without tolerance, for information purposes only.



---

## **Sales and support**

Elithion LLC

393 Iris Ave  
Boulder CO  
80301  
USA

1-303-413-1500

[support@lithionbms.com](mailto:support@lithionbms.com)

Elithion.com