

- Nominal Operating Voltage.....3.2VDC
- Nominal Capacity.....2.4Ah
- Internal impedance (1kHz, AC).....8mOhm
- Internal resistance (20A, 1s, DC).....12mOhm
- Standard Charge.....CC 1200mA to 3.65V, CV to 100mA
- Discharge current (continuous).....20A
- Discharge current (peak, 10sec).....50A
- Discharge cutoff.....2.0V
- Operating temperature range.....-30C to 60C
- Storage temperature range.....-40C to 60C
- Diameter.....26mm
- Length.....65mm
- Weight.....84g
- Part Number.....1004114

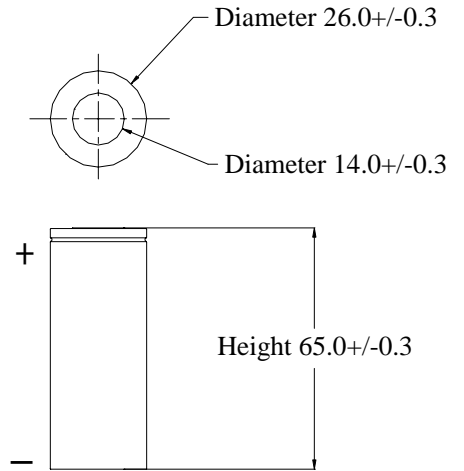

Discharge Temperature Characteristics

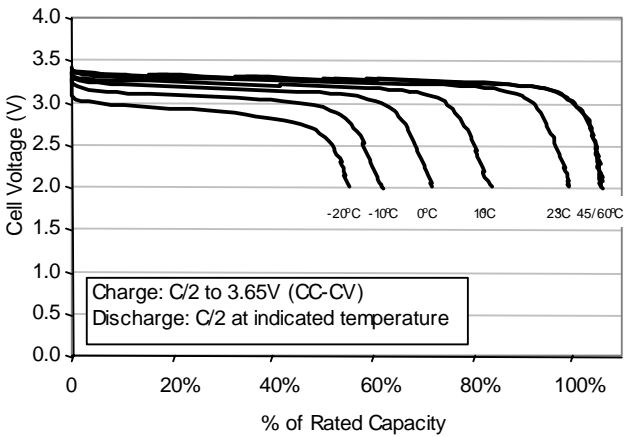

Discharge Rate Characteristics

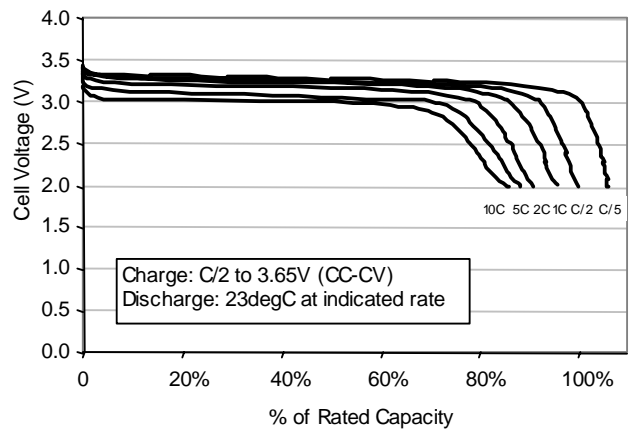

Lifecycle at Standard Rate, Various Temperatures

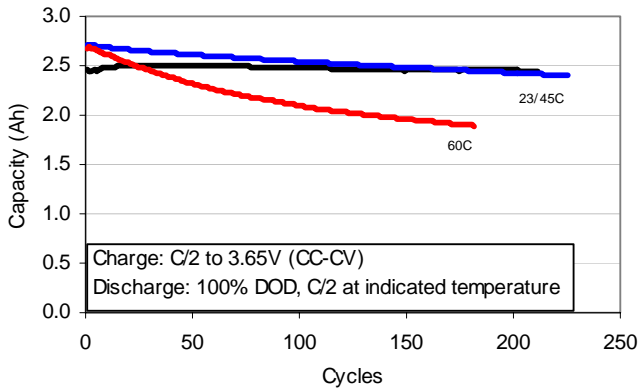

Lifecycle at Maximum Continuous Discharge Rate

